



FEATURES

- Pluggable Interactive HMI for MiBRX-6M Series PLC
- 5 User Configurable Keys
- 2 Line x 8 Character LCD Display
- Size: 105 x 45mm

SPECIFICATIONS

Display Type	8 (Characters) x 2 (Lines) LCD
Backlight Colour	Yellow-Green
Text Colour	Black
No. of Keys	6 (5 User Configurable)
FUNCTIONAL SPECIFICATIONS (CPU)	
Programming Language	Windows based User Friendly SELPRO Software for HMI Configuration and Programming
ENVIRONMENTAL CONDITIONS	
Operating Temperature	0 to 55°C
Storage Temperature	-20 to 70°C
Humidity (non-condensing)	95%
Mounting	Pluggable connection over Din Rail Mounted MiBRX-6M Series PLC
Weight	Approx. 70 gms

⚠ SAFETY PRECAUTIONS

This manual is meant for personnel involved in wiring installation, operation and routine maintenance of the equipment.

All safety related conditions, symbols and instructions that appear in this operating manual or on the equipment must be strictly followed to ensure operator and instrument safety. Any misuse may impair the protection provided by the equipment.

⚠ CAUTION : Read complete instructions prior to installation and operation of the unit. The equipment in its installed state must not come in proximity to any heating sources, caustic vapors, oils, steam or any other unwanted process by-products.

⚠ CAUTION : Risk of Electric Shock.

INSTALLATION INSTRUCTIONS

⚠ CAUTION

1. This equipment, being pluggable-type, normally becomes a part of the main PLC device which is used mainly in control panel and becomes accessible to the user after installation.
2. Conductors must not come in contact with the internal circuitry of the equipment else it may lead to a safety hazard that may endanger life or cause electrical shock to the operator.
3. While installing, ensure power to main PLC equipment is switched OFF. In case of replacement of this equipment with any other type, programming of main PLC equipment needs to be modified accordingly.
4. The equipment shall not be installed in environmental conditions other than those specified in this manual.
5. Thermal dissipation of equipment is met through ventilation holes provided on the housing of the main PLC.

MENU DESCRIPTION

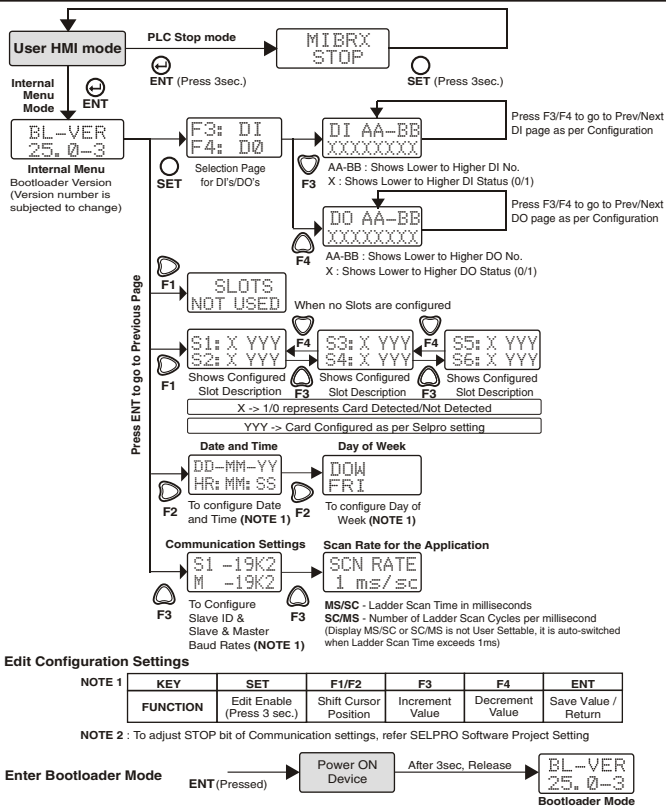

NOTE : For Display Nomenclature, refer MiBRX-6M-1-1-1-230V Operating Instruction

? SERVICE DETAILS

This device contains no user serviceable parts and requires special equipment and specialized engineers for repair.

Maintenance: Do not use Isopropyl alcohol or any other organic solvents for cleaning.

Please contact service center for repair on the following numbers : **Tel. No.** : +91-7498077172

Email : service@selec.com

(Specifications are subject to change, since development is a continuous process.)

Selec Controls Pvt. Ltd., India

Factory Address : EL-27/1, Electronic Zone, TTC Industrial Area, MIDC, Mahape, Navi Mumbai- 400 710, INDIA.

Tel. No : +91-22-41 418 419/430 | Fax No. : +91-22-28471733

Toll free : 1800 227 353 (BSNL/MTNL Subscribers only)

Website : www.selec.com | Email : sales@selec.com