



96mm x 96mm

SPECIFICATIONS

Display	: Liquid crystal display with backlight of 4 lines, 4 digits per line to show electrical Parameters 5th line, 8 digits to show energy Bar graph Current indication as percentage of CT rating
LCD Indications	: - Integration of energy - Unit is in configuration menu - Communication in progress MAX DMD - Maximum & Minimum Demand of Power
Wiring Input	: 3 Ø - 4 wire, 1 Ø - 2 wire - P1, 3 Ø - 3 wire
MID certified Wiring Input	: 3 Ø - 4 wire, 3 Ø - 3 wire
Rated Input Voltage	: 3x230/400V
Installation Category	: III (300V L-N)
Frequency Range	: 45 to 65Hz (MID certified at 50Hz)
CT Primary	: 1/5A...6,000A (Programmable for any Value)
CT Secondary	: 1 or 5A (x1.2)
PT Primary	: 100V...600V (Programmable for any value)
PT Secondary	: 173...415V AC (L-L) (Programmable for any value)
Display Update Time	: 1 second for all parameters
Display Scrolling	: Automatic / Manual
Auxiliary	: 85...270V AC, 47...63Hz
Temperature	: Operating: -10°C...55°C Storage: -20°C...75°C
Humidity	: 85% non-condensing
Mounting	: Panel mounting
Protection Class	: Class II
Pollution Degree	: 2
Meter Type	: Indoor
Weight	: 318gms
IP rating	: IP54 Front only (When fitted with rubber gasket)
Pulse Output	: External 5...27VDC max./100mA max. Pulse Duration: Selectable 50...300ms Pulse Resolution: Selectable 0.01...99.99kWh
Communications	: RS485 Modbus RTU

The meter is intended to be installed in Mechanical Environment 'M1', with Shock and Vibrations of low significance, as per 2004/22/EC Directive.
The meter is intended to be installed in Electromagnetic Environment 'E2', as per 2004/22/EC Directive.

ORDER INFORMATION

Product	Outputs	Certification	
MFM384-C-CU-MID	RS485 (Modbus RTU) & Pulse	CE	MID

SERIAL COMMUNICATION

Interface standard and protocol	RS485 AND MODBUS RTU
Communication address	1...255
Transmission Mode	Half duplex
Data types	Float, Hex and Integer
Transmission distance	500 Meter maximum
Transmission speed	300, 600, 1200, 2400, 4800, 9600, 19200 (in bps)
Parity	None, Odd, Even
Stop bits	1 or 2

ACCURACY

Measurement	Accuracy	Measurement	Accuracy
Voltage V_{L-N}	±0.5% of F.S.	Power factor	±0.01 (Digit)
Voltage V_{L-L}	±0.5% of F.S.	Active energy	EN50470-3: Cl.B
Current	±0.5% of F.S.	Reactive energy	Class 2
Frequency	±0.1% of F.S.	Apparent energy	Class 1
For L-N > 20V, For L-L > 35V		MAX/MIN Active Power	1%
Active Power	1%	MAX/MIN Reactive Power	1%
Apparent power	1%	MAX Apparent Power	1%
Reactive Power	1%		

(F.S - Full Scale)

NOTE

TO COMPLY WITH MID CERTIFICATION THE CT RATIO MUST BE SET BEFORE PUTTING THE METER INTO SERVICE

RESOLUTION

PT Ratio x CT Ratio	kWh / kVAh / kVarh	Pulse
<15	0.01K	0.001K
<150	0.1K	0.01K
<1500	1K	0.1K
<15000	0.01M	1K
<150000	0.1M	0.01M
≥1500000	1M	0.1M

NOTE : 1) For Voltage, Current and Power, resolution is automatically adjusted.
2) For power factor, resolution is 0.001
3) blinks after every 5 sec, if load is connected on any one of 3 phases.

SAFETY PRECAUTIONS

Safety related notifications, symbols and instructions that appear in this operating manual or on the equipment must be strictly followed to ensure the safety of personnel as well as the instrument.

If the equipment is not used in a manner specified by the manufacturer it may impair the protection provided by the equipment.

Do not use the equipment if there is any mechanical damage.

Ensure that the equipment is supplied with correct voltage.

No repairs, maintenance or adjustments are possible.

CAUTION

1. Read complete instructions prior to installation or operation of the unit.
2. Risk of electric shock. Only to be installed by competent personnel.
3. The equipment in its installed state must not come in close proximity to any heating sources, oils, steam, caustic vapors or other unwanted process by-products.

WIRING GUIDELINES

1. To prevent the risk of electrocution, always isolate the power supply to the equipment prior to undertaking any work. Always confirm absence of supply prior to starting work using appropriate voltage detection equipment.
2. Wiring shall be done strictly according to the terminal layout. Confirm that all connections are correct before energizing the equipment.
3. To reduce electromagnetic interference use of wires with adequate ratings and twists of equal size are recommended. All connection should be kept as short as possible.
4. Routing of connecting cables shall be away from any internal EMI source.
5. All cables used for connections must have a cross section of 0.5mm² to 2.5mm². (20 to 14AWG ; 75°C (min))
6. Copper cable should be used. (stranded or solid core cable)
7. All wiring to be in accordance with applicable local standards.

CONFIGURATION LOCK PARAMETER DESCRIPTION

NOTE: After entering the configuration mode, if any of the below mentioned parameters are changed, the user has only 15 minutes to make changes. After 15 minutes the below parameters will get locked and cannot be changed. Power ON/OFF in between will also lock the parameters. The Meter can only be unlocked by returning it to the factory for removal of the lock out.

- | | |
|----------------------|--------------------|
| 1. Network Selection | 6. PT secondary |
| 2. CT Primary | 7. Pulse width |
| 3. CT Secondary | 8. Pulse Duration |
| 4. PT Primary | 9. Factory default |
| 5. Energy Reset | |

MID ANTI-TAMPERING PROVISION

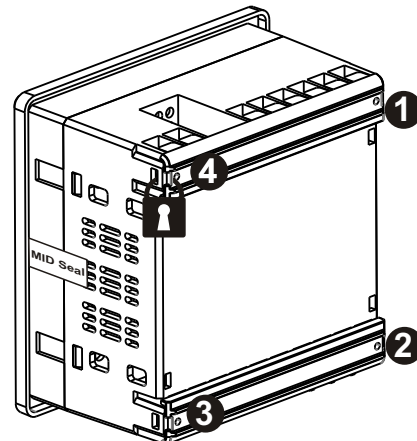

NOTE:

	Points 1, 2, 3 & 4 provided for locking.
MID Seal	Sticker used for sealing the case.

FRONT PANEL DESCRIPTION

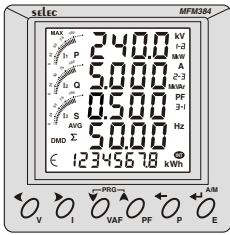

ONLINE PAGE DESCRIPTION

There are 6 dedicated keys labeled as V, I, VAF, PF, P, E. Use these 6 keys to view meter parameters.
If no key is pressed for 60 sec then it returns to default page i.e Total import active energy

KEY PRESS	ONLINE PAGE DESCRIPTION
Press "V"	<p>The first screen : Displays line to neutral Voltage of three phases and average line to neutral voltage.</p> <p>The second screen : Displays line to line voltage of three phases and average line to line voltage.</p> <p>The third screen : Displays total percentage harmonics of line to neutral voltage of three phases and average line to neutral voltage.</p> <p>The fourth screen : Displays total percentage harmonics of line to line voltage of three phases and average line to line voltage.</p> <p>The fifth screen : Press for 3 sec, Displays phase sequence indication. (Clockwise, Anticlockwise, Invalid)</p> <p>Note : 1) For 3 Ø 3 wire system, for only the 2nd, 4th and 5th screen will be available. 2) In 1 Ø 2 wire system only 1st, 3rd and 5th screen will be available.(1st phase parameter will be display).</p>
Press "I"	<p>The first screen : Displays phase current of three phase and neutral current.</p> <p>The second screen : Displays phase maximum current demand of three phases and average current.</p> <p>The third screen : Displays total percentage harmonic of current of three phases and average phase current.</p> <p>Note : 1) For 3 Ø 3 wire system only 1st, 2nd and 3rd screen will be available. Displays average current instead of neutral current. 2) In 1Ø2wire system only 1st phase parameter will be available</p>
Press "VAF"	<p>The first screen : Displays voltage, current, power factor of first phase and frequency.</p> <p>The second screen : Displays voltage, current, power factor of second phase and frequency.</p> <p>The third screen : Displays voltage, current, power factor of third phase and frequency.</p> <p>The fourth screen : Displays average value of voltage, current and power factor of three phases and frequency.</p> <p>Note : 1)In 3 Ø 3 wire system voltage current power factor and frequency will be line to line. 2) In 1 Ø 2 wire system only 1st screen will be available.</p>
Press "PF"	<p>The first screen : Displays power factor of three phases and average power factor.</p> <p>Note : 1) For 3 Ø 3 wire system, only average power factor will be available on this screen. 2) In 1 Ø 2 wire system only 1st phase power factor will be available.</p>
Press "P"	<p>The first screen : Displays active power of three phases and total active power.</p> <p>The second screen : Displays reactive power of three phases and total reactive power.</p> <p>The third screen : Displays apparent power of three phases and total apparent power.</p> <p>The fourth screen : Displays active, reactive, apparent power and power factor of first phase.</p> <p>The fifth screen : Displays active, reactive, apparent power and power factor of second phase.</p> <p>The sixth screen : Displays active, reactive, apparent power and power factor of third phase.</p> <p>The seventh screen : Displays total active, reactive, apparent power and average power factor of three phases.</p> <p>The eighth screen : Displays maximum active power demand, reactive power demand and apparent power demand.</p> <p>The ninth screen : Displays minimum active power demand and reactive power demand.</p> <p>Note : 1) For 3 Ø 3 wire system only 7th, 8th and 9th screen will be available. 2)In 1Ø2wire system only 1st, 2nd, 3rd, 4th, 8th & 9th screen will be available (1st phase parameters will be display)</p>

DECLARATION OF CONFORMITY

We, Selec Control Pvt Ltd declares under our sole responsibility as the manufacturer that the MFM384-C-CU-MID meter described within this manual corresponds to the production model described in the EC-type examination certificate and to the requirement of the 2014/22/EC Directive EC type examination certificate number 0120/SGS0411.

KEY PRESS	ONLINE PAGE DESCRIPTION
Press "E"	<p>The first Screen : Displays import active energy of first phase.</p> <p>The second screen : Displays import active energy of second phase.</p> <p>The third screen : Displays import active energy of third phase.</p> <p>The fourth screen : Displays export active energy of first phase.</p> <p>The fifth screen : Displays export active energy of second phase.</p> <p>The sixth screen : Displays export active energy of third phase.</p> <p>The seventh screen : Displays total import active energy of three phases.</p> <p>The eighth screen : Displays total export active energy of three phases.</p> <p>The ninth screen : Displays total net active energy of three phases.</p> <p>The tenth Screen : Displays import reactive energy of first phase.</p> <p>The eleventh screen : Displays import reactive energy of second phase.</p> <p>The twelveth screen : Displays import reactive energy of third phase.</p> <p>The thirteenth screen : Displays export reactive energy of first phase.</p> <p>The fourteen screen : Displays export reactive energy of second phase.</p> <p>The fifteen screen : Displays export reactive energy of third phase.</p> <p>The sixteen screen : Displays total import reactive energy of three phases.</p> <p>The seventeenth screen : Displays total export reactive energy of three phases.</p> <p>The eighteen screen : Displays total net reactive energy of three phases.</p> <p>The nineteenth screen : Displays apparent energy of first phase.</p> <p>The twenty screen : Displays apparent energy of second phase.</p> <p>The twenty first screen : Displays apparent energy of third phase.</p> <p>The twenty second screen : Displays total net apparent energy of three phases.</p> <p>The twenty third screen : Displays run hour. (Increment by 0.01hr after every 36 sec.)</p> <p>NOTE : 1) For 1 phase 2 wire only 1st, 4th, 7th, 8th, 9th, 10th, 13th, 16th, 17th,18th, 19th, 22nd & 23rd screen will be available. 2) In 3 phase 3 wire network 9th, 18th, 22nd & 23rd screen will be display</p>

DEVICE IDENTIFICATION

Press PF key for 10 sec, displays CRC in first two row, HW & SW version no. in 3rd and 4th row & serial no. in last row.

AUTOMATIC / MANUAL PAGE SCROLLING

Press E (↔) button for 3 seconds to toggle between Automatic and Manual mode.

Note : By default unit operates in automatic mode.

In automatic mode online pages scroll automatically at the rate of 5 seconds per page. All the time, total import active energy will be displays & at any other page of energy if no key is pressed for 1 min.

In automatic mode when any key is pressed, unit temporarily switches to manual mode and the appropriate page is displayed, also if no key is pressed for 5 sec, unit resumes automatic mode.

CURRENT CONNECTION INDICATION

Press I key for 3 sec. to check the current connection. If current connection reverse meter will show in which phase connection is reversed.

- 0 - No any phase
- 1 - 1st phase
- 2 - 2nd phase
- 3 - 3rd phase

PROGRAMMING MENU

There are 6 dedicated keys with symbols marked as ◀, ▶, ▲, ▼, ←, → use these 6 keys to enter into the configuration menu and to change values.

NOTE : The settings should only be modified by a competent person after having read this users manual fully and having understood the application. (Please refer to configuration lock note on Page 1 before entering into configuration mode)

Key functions:

Press ▲ + ▼ keys for 3 sec to enter or exit from the configuration menu.

Use ◀ or ▶ keys to move cursor left or right by one digit each time.

Use ▲ or ▼ keys for increasing or decreasing parameters value.

Use ← key to go back to previous page.

Use → key to save the setting and move on to next page.

Config. page.	Function	Range or Selection	Factory Setting
	Password	0000 to 9998	1000
1	Change Password	No / Yes	No
1.1	New Password	0000 to 9998	0000
2	Network Selection	3P4W, 3P3W, 1P2W-P1	3P4W
3	CT Secondary	1A or 5A	5
4	CT Primary	1A/5A to 6,000A	5
5	PT Secondary	173V to 415V	350
6	PT primary	100V to 600V	350
7	Slave Id	1 to 255	1
8	Baud Rate	300, 600, 1200, 2400, 4800, 9600 and 19200	9600
9	Parity	None, Even, Odd	None
10	Stop Bit	1 or 2	1
11	BackLight	0 to 7200 sec.	0000
12	Demand interval method	Sliding / Fixed	Sliding
13	Demand interval duration	1 to 30	15
14	Demand interval length	1 to 30 min	1
15	Max Page Auto	1 to 21	21
16	Change Page Sequence	No / Yes	No
16.01	Page sequence 1	Page 1 to 21	1
16.02	Page sequence 2	Page 1 to 21	2
16.03	Page sequence 3	Page 1 to 21	3
16.04	Page sequence 4	Page 1 to 21	4
16.05	Page sequence 5	Page 1 to 21	5
16.06	Page sequence 6	Page 1 to 21	6
16.07	Page sequence 7	Page 1 to 21	7
16.08	Page sequence 8	Page 1 to 21	8
16.09	Page sequence 9	Page 1 to 21	9
16.10	Page sequence 10	Page 1 to 21	10
16.11	Page sequence 11	Page 1 to 21	11
16.12	Page sequence 12	Page 1 to 21	12
16.13	Page sequence 13	Page 1 to 21	13
16.14	Page sequence 14	Page 1 to 21	14
16.15	Page sequence 15	Page 1 to 21	15
16.16	Page sequence 16	Page 1 to 21	16
16.17	Page sequence 17	Page 1 to 21	17
16.18	Page sequence 18	Page 1 to 21	18
16.19	Page sequence 19	Page 1 to 21	19
16.20	Page sequence 20	Page 1 to 21	20
16.21	Page sequence 21	Page 1 to 21	21
17	Pulse Weight	00.01 to 99.99	0.10
18	Pulse duration	50 to 300	200
19	Factory Default	No / Yes	No
20	Reset Energy & Max Demand	No / Yes	No
20.1	Password	0001 To 9999	0000
20.01	Reset Active Energy	No / Yes	No
20.02	Reset Reactive Energy	No / Yes	No
20.03	Reset Apparent Energy	No / Yes	No
20.04	Reset Max Power	No / Yes	No
20.05	Reset Run Hour	No / Yes	No

• For resetting energy parameters user will be prompted for password. If correct password is entered, the user will be able to reset parameters. This password will be greater than the configuration password by 1.

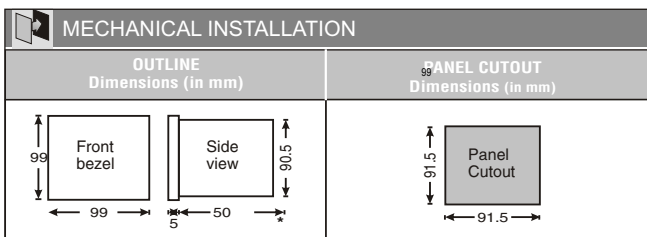

For installing the meter.

1. Prepare the panel cutout with dimensions as shown.
2. Push the meter into panel cutout. Secure the meter in the place by fitting the clamps from rear side, diagonally opposite for optimum fitting.
3. For proper sealing, tighten the screws evenly with required torque.
4. Recommended conductor cross section=1.5mm².
Screw clamp tightening torque=0.1 N-m

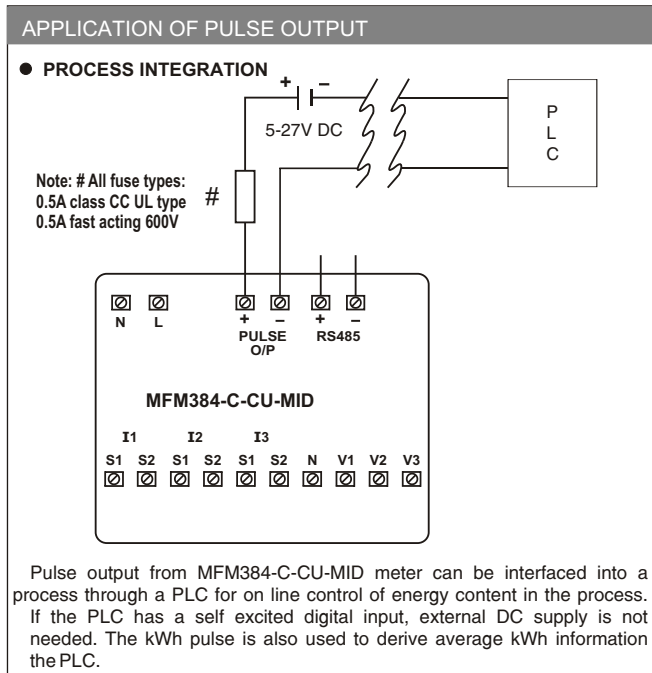
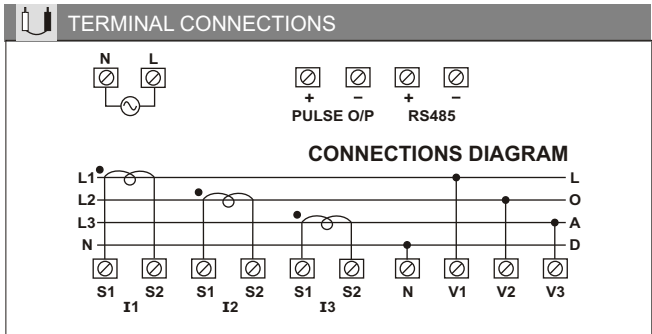
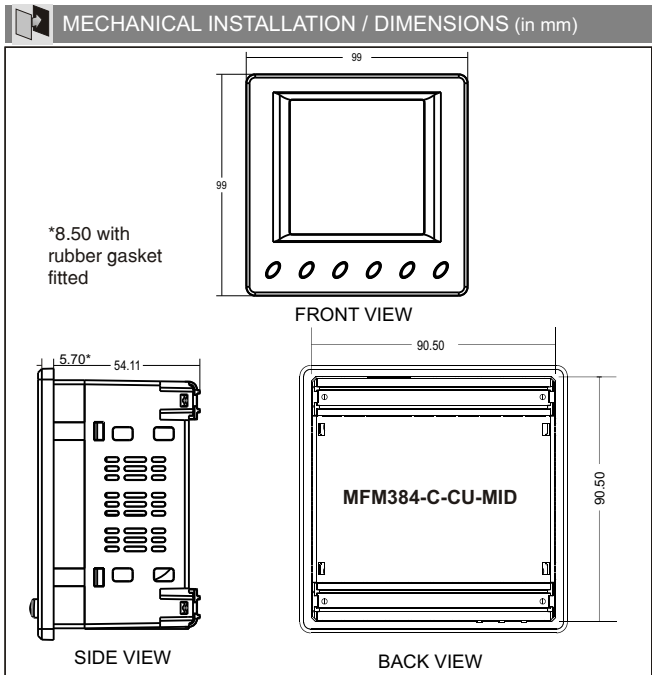

MODBUS REGISTER ADDRESSES LIST			Readable / writable parameters : [Data Structure : Integer]		
Address	Hex Address	Parameter	Range		Length (Register)
40000	0x00	Password	Min value : 0	Max value : 9998	1
40007	0x07	Slave id	Value : 1	Meaning : 255	1
40008	0x08	Baud rate	Value : 0x0000	Meaning : 300	1
			Value : 0x0001	Meaning : 600	
			Value : 0x0002	Meaning : 1200	
			Value : 0x0003	Meaning : 2400	
			Value : 0x0004	Meaning : 4800	
			Value : 0x0005	Meaning : 9600	
			Value : 0x0006	Meaning : 19200	
40009	0x09	Parity	Value : 0x0000	Meaning : None	1
			Value : 0x0001	Meaning : Odd	
			Value : 0x0002	Meaning : Even	
40010	0x0A	Stop bit	Value : 0x0000	Meaning : 1	1
			Value : 0x0001	Meaning : 2	1
40011	0x0B	Backlight OFF	Min value : 0	Max Value : 7200	1
40016	0x10	Auto Mode Pages	Min Value : 1	Max Value : 21	
40017	0x11	Page Address Sequence	Page No : 1-21	Meaning : 1-First Page ; 21-Last Page	1
40018	0x12	Page Address Sequence	Page No : 1-21	Meaning : 1-First Page ; 21-Last Page	1
40019	0x13	Page Address Sequence	Page No : 1-21	Meaning : 1-First Page ; 21-Last Page	1
40020	0x14	Page Address Sequence	Page No : 1-21	Meaning : 1-First Page ; 21-Last Page	1
40021	0x15	Page Address Sequence	Page No : 1-21	Meaning : 1-First Page ; 21-Last Page	1
40022	0x16	Page Address Sequence	Page No : 1-21	Meaning : 1-First Page ; 21-Last Page	1
40023	0x17	Page Address Sequence	Page No : 1-21	Meaning : 1-First Page ; 21-Last Page	1
40024	0x18	Page Address Sequence	Page No : 1-21	Meaning : 1-First Page ; 21-Last Page	1
40025	0x19	Page Address Sequence	Page No : 1-21	Meaning : 1-First Page ; 21-Last Page	1
40026	0x1A	Page Address Sequence	Page No : 1-21	Meaning : 1-First Page ; 21-Last Page	1
40027	0x1B	Page Address Sequence	Page No : 1-21	Meaning : 1-First Page ; 21-Last Page	1
40028	0x1C	Page Address Sequence	Page No : 1-21	Meaning : 1-First Page ; 21-Last Page	1
40029	0x1D	Page Address Sequence	Page No : 1-21	Meaning : 1-First Page ; 21-Last Page	1
40030	0x1E	Page Address Sequence	Page No : 1-21	Meaning : 1-First Page ; 21-Last Page	1
40031	0x1F	Page Address Sequence	Page No : 1-21	Meaning : 1-First Page ; 21-Last Page	1
40032	0x20	Page Address Sequence	Page No : 1-21	Meaning : 1-First Page ; 21-Last Page	1
40033	0x21	Page Address Sequence	Page No : 1-21	Meaning : 1-First Page ; 21-Last Page	1
40054	0x36	Page Address Sequence	Page No : 1-21	Meaning : 1-First Page ; 21-Last Page	1
40055	0x37	Page Address Sequence	Page No : 1-21	Meaning : 1-First Page ; 21-Last Page	1
40059	0x3B	Page Address Sequence	Page No : 1-21	Meaning : 1-First Page ; 21-Last Page	1
40060	0x3C	Page Address Sequence	Page No : 1-21	Meaning : 1-First Page ; 21-Last Page	1
40034	0x22	Demand Interval Method	Value : 0x0000	Meaning : Sliding	1
			Value : 0x0001	Meaning : Fixed	
40035	0x23	Demand Interval Duration	MIN Value : 1	MAX Value : 30	1
40036	0x24	Demand Interval Length	MIN Value : 1	MAX Value : 30	1
40043	0x2B	Reset Max	Value : 1	Meaning : Reset all Max power & Max Current	1
40045	0x2D	Reset Run Hour	Value : 1	Meaning : Reset Run hour	1

MODBUS REGISTER ADDRESSES LIST				Readable Parameters : [Length (Register) : 2 ; Data Structure : Float]	
Formula to find address of individual Harmonic					
Constant Parameter	Meaning	Constant Parameter	Meaning		
0	Voltage V1N	5	Voltage V31		
1	Voltage V2N	6	Current I1		
2	Voltage V3N	7	Current I2		
3	Voltage V12	8	Current I3		
4	Voltage V23	—	—		
				$\{143 + [(Harmonic\ no-2) \times 2] + 60 \times Constant\ Parameter\}$	
				For Example, To find the 14 th Harmonic address of Voltage V31 following formula can be used :	
				Formula with the parameter : $\{143 + [(Harmonic\ no-2) \times 2] + 60 \times C\ P\}$ Eg. $\{143 + [(14-2) \times 2] + 60 \times 5\} = 467$	
				So, Check the 14 th Harmonic of Voltage V31 at 467 address.	

MODBUS REGISTER ADDRESSES LIST

Readable Parameters : [Length (Register) : 2 ; Data Structure : Float]

Address	Hex Address	Parameter	Address	Hex Address	Parameter	Address	Hex Address	Parameter
30000	0x00	Voltage V1N	30056	0x38	Frequency	30112	0x70	Total kVArh (Imp)
30002	0x02	Voltage V2N	30058	0x3A	Total net kWh	30114	0x72	Total kVArh (Exp)
30004	0x04	Voltage V3N	30060	0x3C	Total net kVAh	30116	0x74	kVAh1
30006	0x06	Average Voltage LN	30062	0x3E	Total net kVArh	30118	0x76	kVAh2
30008	0x08	Voltage V12	30064	0x40	kW Max Active Power	30120	0x78	kVAh3
30010	0x0A	Voltage V23	30066	0x42	kW Min Active Power	30122	0x7A	Neutral Current
30012	0x0C	Voltage V31	30068	0x44	kVAr Max Reactive Power	30124	0x7C	THD of 1st Phase Voltage
30014	0x0E	Average Voltage LL	30070	0x46	kVAr Min Reactive Power	30126	0x7E	THD of 2nd Phase Voltage
30016	0x10	Current I1	30072	0x48	kVA Max Apparent Power	30128	0x80	THD of 3rd Phase Voltage
30018	0x12	Current I2	30074	0x4A	MAX I1 Demand	30130	0x82	THD of Voltage V12
30020	0x14	Current I3	30076	0x4C	MAX I2 Demand	30132	0x84	THD of Voltage V23
30022	0x16	Average Current	30078	0x4E	MAX I3 Demand	30134	0x88	THD of Voltage V31
30024	0x18	kW1	30080	0x50	MAX Avg Demand	30136	0x8A	THD of Current I1
30026	0x1A	kW2	30082	0x52	Run hour	30138	0x8C	THD of Current I2
30028	0x1C	kW3	30084	0x54	kWh1 (Imp)	30140	0x8E	THD of Current I3
30030	0x1E	kVA1	30086	0x56	kWh2 (Imp)	30684	0x2AC	Serial no. (Data Structure : Hex)
30032	0x20	kVA2	30088	0x58	kWh3 (Imp)	30700	0x2BC	Phase Sequence Indication (Data structure: Integer) 0 - Clockwise 1 - Anticlockwise 2 - Invalid
30034	0x22	kVA3	30090	0x5A	kWh1 (Exp)	30702	0x2BE	Existing kW MAX Active Power
30036	0x24	kVAr1	30092	0x5C	kWh2 (Exp)	30704	0x2C0	Existing kW MIN Active Power
30038	0x26	kVAr2	30094	0x5E	kWh3 (Exp)	30706	0x2C2	Existing kVAr MAX Reactive Power
30040	0x28	kVAr3	30096	0x60	Total kWh (Imp)	30708	0x2C4	Existing kVAr MIN Reactive Power
30042	0x2A	Total KW	30098	0x62	Total kWh (Exp)	30710	0x2C6	Existing kVA MAX Apparent Power
30044	0x2C	Total kVA	30100	0x64	kVArh1 (Imp)	30712	0x2C8	Existing MAX I1 Demand
30046	0x2E	Total kVAr	30102	0x66	kVArh2 (Imp)	30714	0x2CA	Existing MAX I2 Demand
30048	0x30	PF1	30104	0x68	kVArh3 (Imp)	30716	0x2CC	Existing MAX I3 Demand
30050	0x32	PF2	30106	0x6A	kVArh1 (Exp)	30718	0x2CE	Existing MAX Avg. I Demand
30052	0x34	PF3	30108	0x6C	kVArh2 (Exp)			
30054	0x36	Average PF	30110	0x6E	kVArh3 (Exp)			

NOTE : LSB will be displayed on lower address and MSB will be displayed on higher address.

Readable parameters : [Data Structure : Hex]

Address	Hex Address	Parameter	Length	Address	Hex Address	Parameter	Length	Address	Hex Address	Parameter	Length
31000	0x3E8	Voltage V1N	2	31042	0x412	Total kW	2	31082	0x43A	Run Hour	2
31002	0x3EA	VoltageV2N	2	31044	0x414	Total kVA	2	31084	0x43C	kWh1(imp)	3
31004	0x3EC	Voltage V3N	2	31046	0x416	Total kVAr	2	31087	0x43F	kWh2(imp)	3
31006	0x3EE	Average Voltage LN	2	31048	0x418	Neutral Current	2	31090	0x442	kWh3(imp)	3
31008	0x3F0	Voltage V12	2	31050	0x41A	PF1	1	31093	0x445	kWh1(Exp)	3
31010	0x3F2	Voltage V23	2	31051	0x41B	PF2	1	31096	0x448	kWh2(Exp)	3
31012	0x3F4	Voltage V31	2	31052	0x41C	PF3	1	31099	0x44B	kWh3(Exp)	3
31014	0x3F6	Average VoltageLL	2	31053	0x41D	Avg PF	1	31102	0x44E	Total kWh (Imp)	3
31016	0x3F8	Current I1	2	31054	0x41E	Total net kWh	3	31105	0x451	Total kWh (Exp)	3
31018	0x3FA	Current I2	2	31057	0x421	Total net kVAh	3	31108	0x454	kVArh1(Imp)	3
31020	0x3FC	Current I3	2	31060	0x424	Total net kVArh	3	31111	0x457	kVArh2(Imp)	3
31022	0x3FE	Average current	2	31063	0x427	Frequency	1	31114	0x45A	kVArh3(Imp)	3
31024	0x400	kW1	2	31064	0x428	kW max Active Power	2	31117	0x45D	kVArh1(Exp)	3
31026	0x402	kW2	2	31066	0x42A	kW Min Active Power	2	31120	0x460	kVArh2(Exp)	3
31028	0x404	kW3	2	31068	0x42C	kVAr Max Reactive Power	2	31123	0x463	kVArh3(Exp)	3
31030	0x406	kVA1	2	31070	0x42E	kVAr Min Reactive Power	2	31126	0x466	Total kVArh(Imp)	3
31032	0x408	kVA2	2	31072	0x430	kVA Max Apparent Power	2	31129	0x469	Total kVArh(Exp)	3
31034	0x40A	kVA3	2	31074	0x432	Max I1 Demand	2	31132	0x46C	kVAh1	3
31036	0x40C	kVAr1	2	31076	0x434	Max I2 Demand	2	31135	0x46F	kVAh2	3
31038	0x40E	kVAr2	2	31078	0x436	Max I3 Demand	2	31138	0x472	kVAh3	3
31040	0x410	kVAr3	2	31080	0x438	Max Avg Demand	2	---	---	---	---

Note - Voltage and current will display in mV and mA. Power will display in W(Active), VA(Reactive) & VA(Apparent). Energy will display in Wh(Active) VArh(Reactive) & VAh(Apparent)

Energy rollover counter addresses : Energy rollover counter will increment when energy is roll over from 99999999 to 0. [Data Structure : Integer]											
31200	4B0	IMP kWh1 RC*	1	31208	4B8	Total Net kWh RC*	1	31216	4C0	EXP kVArh1 RC*	1
31201	4B1	IMP kWh2 RC*	1	31209	4B9	kVAh1 RC*	1	31217	4C1	EXP kVArh2 RC*	1
31202	4B2	IMP kWh3 RC*	1	31210	4BA	kVAh2 RC*	1	31218	4C2	EXP kVArh3 RC*	1
31203	4B3	EXP kWh1 RC*	1	31211	4BB	kVAh3 RC*	1	31219	4C3	Total IMP kVArh RC*	1
31204	4B4	EXP kWh2 RC*	1	31212	4BC	Total Net kVAh RC*	1	31220	4C4	Total EXP kVArh RC*	1
31205	4B5	EXP kWh3 RC*	1	31213	4BD	IMP kVArh1 RC*	1	31221	4C5	Total Net kVArh RC*	1
31206	4B6	Total IMP kWh RC*	1	31214	4BE	IMP kVArh2 RC*	1	NOTE : RC* : Rollover counter			
31207	4B7	Total EXP kWh RC*	1	31215	4BF	IMP kVArh3 RC*	1	---	---	---	---

3 PHASE-4 WIRE (Commonly Used) 3 Ø - 4 Wire, 3 CT'S

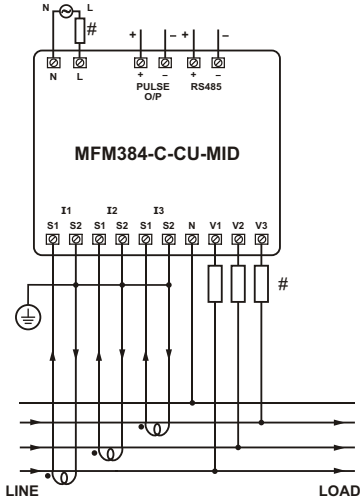

3 PHASE - 4 WIRE 3 Ø - 4 Wire, 3 CT'S and 3 PT'S

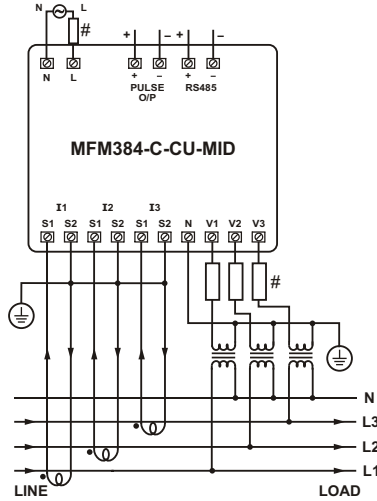

3 PHASE - 3 WIRE 3 Ø - 3 Wire, 2 CT'S

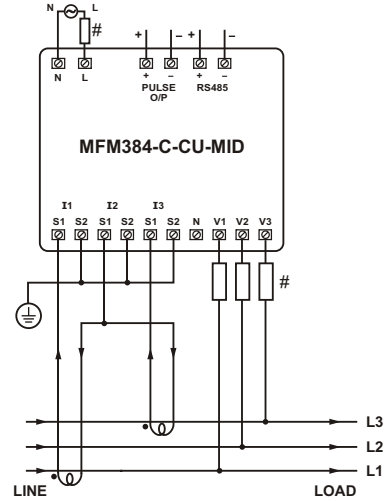

3 PHASE - 3 WIRE 3 Ø - 3 Wire, 2 CT'S and 2 PT'S

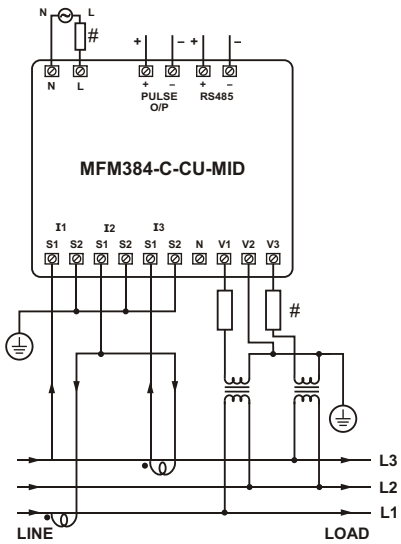

2 PHASE - 3 WIRE 2 Ø - 3 Wire, 2 CT'S

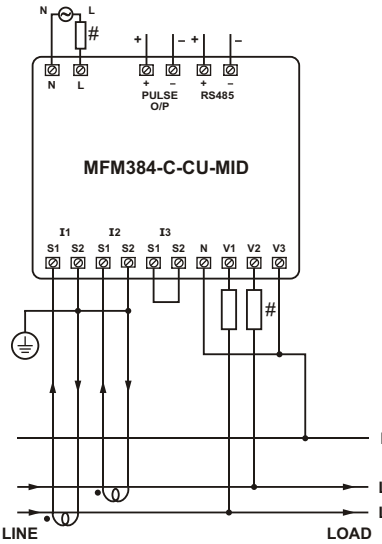

2 PHASE - 3 WIRE 2 Ø - 3 Wire, 2 CT'S and 2 PT'S

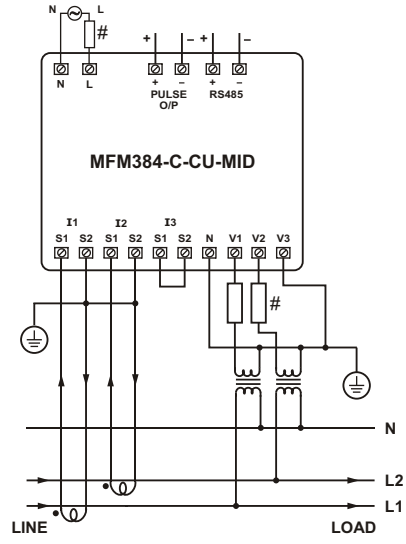

1 PHASE - 2 WIRE 1 Ø - 2 Wire, 1 CT

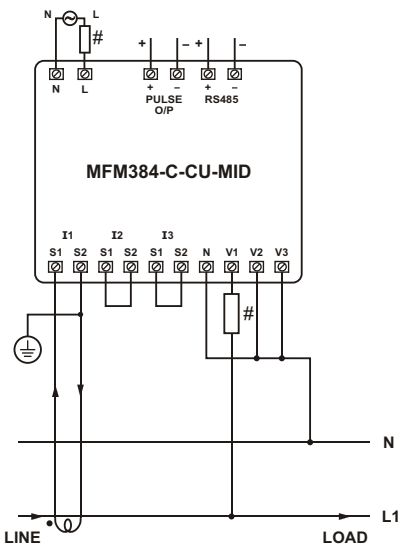

CONNECTION DIAGRAM FOR COMMUNICATION

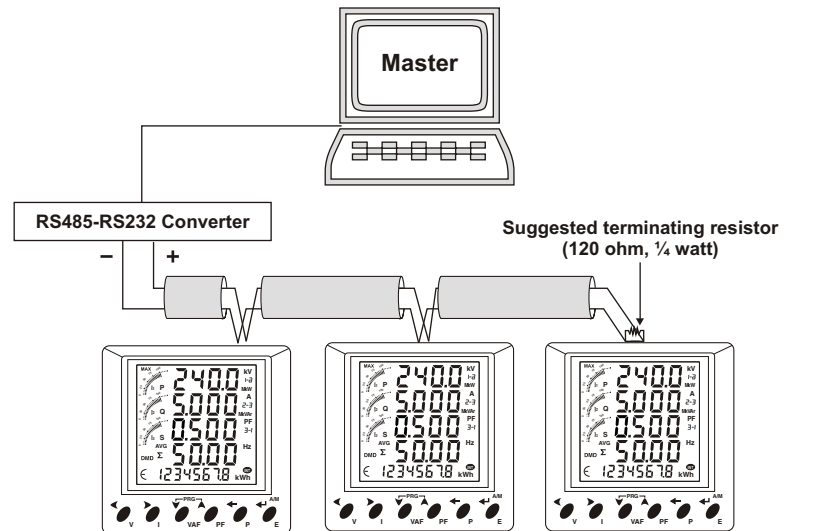

Contact sales for PC based monitoring software to communicate with the meters.

NETWORK SELECTION AND WIRING INPUT

Network selection in configuration mode	Wiring
3P4W	3P4W
3P3W	3P3W
1P2W	1P2W-P1

(Specifications are subject to change, since development is a continuous process.)

Selec Controls Pvt Ltd,
 EL-224, Electronic Zone,
 TTC Industrial Area, MIDC, Mahape
 Navi Mumbai - 400 710 Maharashtra,
 India.