

SELEC XC2200/XC3200, XC2200-C/XC3200-C
Operating Instructions



72 x 72 96 x 96

SPECIFICATIONS

Display	6 (Red) + 4 (Green) digits, 0.43" height, 7 seg LED LED's : 2(Red) +2(Green)
No. of keys	3
Supply Voltage	90 to 270 VAC, 50/60Hz
Sensor Supply	12VDC, 30mA (±10%) (Short circuit protected)
Range	Total : Least count 0.0001, 0.001, 0.01, 0.1, 1 Rate : Auto ranging. RPS, RPM or RPH mode user selectable (minimum frequency for rate mode is 4 RPM)
Set Points	Two set points, each programmable from 0.0001 to 999999
Rate (Rt) / Batch(Bt) Selection	User selectable Rate / Batch at lower display
Relay 2 operation modes	User selectable Relay 2 operation modes 1) Operate on Set2 2) Operate on Set Batch (SPBT)
Operating modes	On delay, Interval, Time pulse repeat, Auto reset
Counting modes	Unidirectional, Quadrature, Bi - directional Directional (Up / Down)
Accuracy	Rate : 0.05% ± 2 counts
Count Inputs	5 to 30VDC from proximity switches, encoders, solid state devices, potential free contacts like limit switches, relays
Maximum Input Frequency	30Hz, 5000Hz
Scale Factor	Programmable form 0.00001 to 9.99999 x 10 ⁿ Where n = -5, -4, -3, -2, -1, 0, 1, 2
Reset Input	1) Front panel (user selectable) 2) Remote reset Minimum reset time for remote reset is 10ms
Relay Output	2 relays, 1C/O each rated 5 A @ 230 VAC / 24 VDC
Memory Retention	10 years
Configuration Lock	Via rear terminals to avoid inadvertent change in configured parameters
Housing	Flame retardant plastic

ORDER CODE INFORMATION

Product	RS485 Communication	Certification	
		CE	UL LISTED
XC2200	—	—	—
XC2200-C	■	—	—
XC3200	—	—	—
XC3200-C	■	—	—
XC2200-CE	—	■	—
XC2200-C-CE	■	■	—
XC3200-CE	—	■	—
XC3200-C-CE	■	■	—

ENVIRONMENTAL CONDITIONS

Temperature	Operating : 0 - 50°C, Storage : -20 - 75°C.
Humidity	95% RH
Mounting	Panel Mounted
Weight	XC2200/XC2200-C : 228gms XC3200/XC3200-C : 263gms

COMMUNICATION (Only applicable to XC2200-C & XC3200-C)

Communication port	RS 485 Slave
Communication Protocol	MODBUS RTU
Baud Rate	9600, 19200, 38400, 57600, 115200 (User configurable via software and hardware) Default= 19200
Default setting	Baud Rate : 19200 Parity : None Stop bit : 2

SAFETY PRECAUTIONS

This manual is meant for personnel involved in wiring, installation, operation and routine maintenance of the equipment. All safety related conditions, symbols and instructions that appear in this operating manual or on the equipment must be strictly followed to ensure operator and instrument safety. Any misuse may impair the protection provided by the equipment.

- CAUTION** : Read complete instructions prior to installation and operation of the unit.
- CAUTION** : Risk of electric shock.

INSTALLATION INSTRUCTIONS

- This equipment, being built-in-type, normally becomes a part of the main control panel and the terminals do not remain accessible to the user after installation.

- Conductors must not come in contact with the internal circuitry of the equipment else it may lead to a safety hazard that may endanger life or cause electrical shock to the operator.
- Circuit breaker or mains switch must be installed between the power source and supply terminals to facilitate power 'ON' or 'OFF' function.
- The equipment shall not be installed in environmental conditions other than those specified in this manual.
- Since this equipment forms part of the main control panel, its output terminals get connected to the host equipment. Such equipment shall also comply to EMI / EMC and safety requirements like CE standard procedure.
- Thermal dissipation of equipment is met through ventilation holes provided on housing of equipment. Obstruction of these ventilation holes may lead to a safety hazard.
- The output terminals shall be loaded strictly as per the values / range specified by the manufacturer.

ELECTRICAL PRECAUTIONS DURING USE

Electrical noise generated by switching of inductive loads can create momentary disruption, erratic display, latch up, data loss or permanent damage to the instrument.

To reduce noise :
Use of Selec make Snubber across load is recommended.

NOTE : Below mentioned diagram is applicable only for 230V relay outputs.

TYPICAL CONNECTIONS FOR LOADS

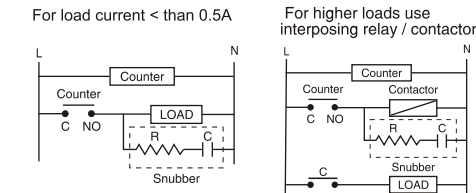

NOTE : a) Use snubber as shown above to increase life of internal relay
b) Use separate shielded wires for inputs.

MECHANICAL INSTALLATION

Outline Dimensions (in mm)	Panel Cutout (in mm)
----------------------------	----------------------

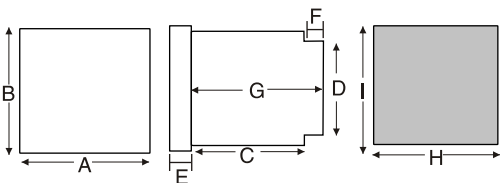

MODELS	DIM	A	B	C	D	E	F	G	H	I
XC2200/XC2200-C		72	72	74	61	5.5	3	91	67	67
XC3200/XC3200-C		96	96	45.5	90.5	3	13	55	90.5	90.5

- For installing the controller
- Prepare the panel cutout with proper dimensions as shown above.
 - Fix the unit into the cutout. Insert the clamp from both sides and tighten the screws.

CAUTION
The equipment in its installed state must not come in close proximity to any heating sources, caustic vapors, Oils, steam, or other unwanted process by products.

- EMC Guidelines :**
- Use proper input power cables with shortest connections and twisted type.
 - Layout of connecting cables shall be away from any internal EMI source.

- MAINTENANCE :**
- To avoid blockage of ventilation holes, clean the equipment regularly using a soft cloth.
 - Do not use Isopropyl alcohol or any other organic Solvents for cleaning.

TERMINAL CONNECTIONS

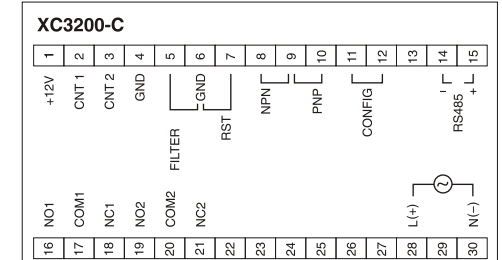
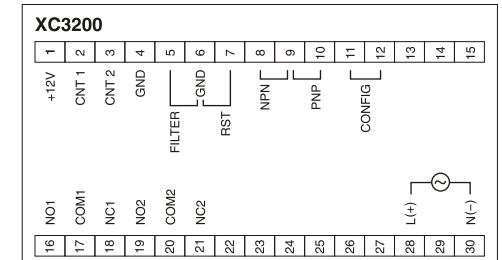
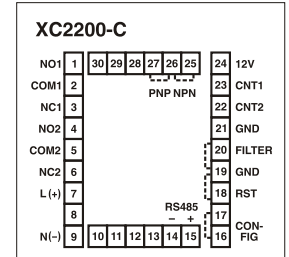
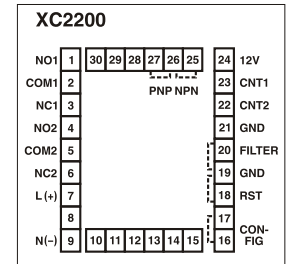

WIRING DIAGRAM FOR COUNT INPUT

(Sensor color codes :-
 Red = +12V, Green = CNT, Black = GND
 Brown = +12V, Black = CNT, Blue = GND)

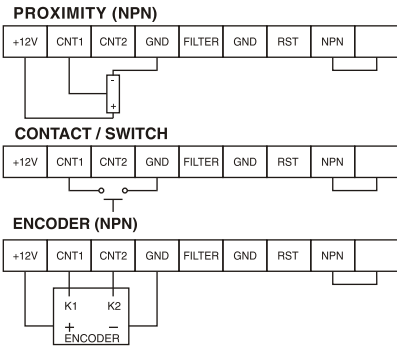

- NOTE :**
1. For PNP sensors, connect 1kohm resistor between CNT and GND terminals
 2. If the sensors (Proximity / Encoder) require more than 30mA current, use external power supply to power the sensors.



CONFIGURATION SCHEME (Parameter setting)

- 1) Short terminal [CONFIG] no 16, 17 for XC2200 / XC2200-C & 11, 12 for XC3200 / XC3200-C
- 2) Turn power on
- 3) Program settings as per instructions given below :
- 4) Value of parameter is stored after pressing Rst key.

Config. Parameter	Display	Description
Scale factor mantissa	Factory setting : 1.00000 *Blinking digit 	▲ Key : Increments the blinking digit after every key press and rolls over from 0 to 9. ▶ Key : Shifts the blinking to next digit (right) for every key press. Range : 0.00001 to 9.99999
Scale factor exponent	Factory setting : 0 *Blinking digit 	Press ▲ Exponent = 0 i.e 10 ⁰ Range : 0 to 2, -5 to -1
Resolution	Factory setting : 1 Blinking 	Range : 0.0001 to 1

Config. Parameter	Display	Description
Reset cumulative total	Factory setting : Rtot 0 Blinking 	Press # No action from rtot 0 - 4 Range : R tot 0, R tot 1, R tot 2, R tot 3, R tot 4, R tot 5 Note : R tot 5 reset count, cumulative total and Batch total.
Reset all (Initialisation)	Factory setting : Rst 0 Blinking 	Note : At Rst 5 reset all, all parameters reset to factory settings. Press # No reset from Rst 0 - 4 Range : Rst 0, Rst 1, Rst 2, Rst 3, Rst 4, Rst 5
NOTE : . To quit configuration mode : 1) Turn power off 2) Remove link between terminal [CONFIG] no 16, 17 for XC2200 / XC2200-C & 11, 12 for XC3200 / XC3200-C 3) Turn power on		

Config. Parameter	Display	Description
To program SET 1, SET 2 / SPBT & AR / TPR time:		
	Key :Press for 3 sec. From count mode.	
	Key :Increments the blinking digit after every key press and rolls over from 0 to 9	
	Key :Shifts the blinking to next digit (right) for every key press	
	Key :To complete programming	

Set points	Factory setting : 100 *Blinking digit 	# Set value 1
	Factory setting : 90 *Blinking digit 	Press # Set value 2
	OR Factory setting : 1 *Blinking digit 	OR Press # Set Batch
	AR / TPR time *Blinking digit 	Press # Pulse time Maximum pulse time = 99.9sec
Note: 1) Time parameter is valid for AR and TPR modes. 2) SET1 should always be greater than SET2		

Count & Rate or Count & Batch display		
Count & Rate	When Rate selected in LDSP	Factory setting : Count & Rate # Current Count value # Rate value with Rt (Led 3) on
Count & Batch	When Batch selected in LDSP	OR # Current Count value # Batch value with Bt (Led 4) on

To Read SET 1, SET 2/ SPBT & PULSE TIME VALUES			
SET1	When SET2 is selected for Relay2 operation	Press	# Set value 1
SET2		Press	#Set value 2
SPBT		OR Press	# Set Batch
TIME		Press	# Pulse time

TO READ VALUES OF CONFIGURED PARAMETERS :					
		Key :Read configured parameter when momentary press. # Automatically skips to value after 3 sec			
Parameters	Display	Description	Parameters	Display	Description
Cumulative total	Press	# Cumulative total	Relay operating mode	Press	# Relay operating mode
Batch total	(momentary)	# Batch total with Bt(Led 4)on	Reset mode	Press	# Reset mode
OR	OR	# Cumulative total	Input Frequency	Press	# Input Frequency
Cumulative Rate	(momentary)	# Rate value with Rt(Led 3)on	Rate unit	Press	# Rate unit
Scale factor mantissa	Press	# Scale factor mantissa	Overrun / non overrun mode	Press	# Overrun
Scale factor exponent	(momentary)	# Scale factor exponent	Communication setting	Press	# Baud Rate
Resolution (least count)	Press	# Resolution	Front panel reset	Press	# Slave Id
Counting mode	(momentary)	# Counting mode	Press	# Front panel reset	
Counting direction	(momentary)	# Counting direction	Press		

MODBUS REGISTER ADDRESS LIST							
S.NO	Modbus Address	Hex Address	Parameters	Length (Bits)	Data type	R/W	Description Selection : Data
FSC,FMC,RCS							
1	00004	0 X 04	Relay Operating Mode	1	Bool	R/W	On delay : 0, Interval : 1
2	00005	0 X 05	Count direction	1	Bool	R/W	Up : 0, Down : 1
3	00006	0 X 06	Count Overflow Mode	1	Bool	R/W	Over run : 0, Non over run : 1
4	00007	0 X 07	Input Frequency	1	Bool	R/W	5000 : 0, 30Hz : 1
5	00008	0 X 08	Lower Display selection	1	Bool	R/W	Rate : 0, Batch : 1
6	00009	0 X 09	Relay 2 Operation	1	Bool	R/W	Set 2 : 0, Set Batch : 1
7	00010	0 X 0A	Front panel reset(FPR)	1	Bool	R/W	Yes : 0, No: 1
8	00011	0 X 0B	Reset all	1	Bool	R/W	Set all parameters to factory Default
9	00012	0 X 0C	Reset Batch Count	1	Bool	R/W	Reset Batch Count, Cumulative total,Count Value
10	00013	0 X 0D	Reset Count Value	1	Bool	R/W	Set Count Value to 0

S.NO	Modbus Address	Hex Address	Parameters	Length (Bytes)	Data type	R/W	Description
PSR, PMR, RHR							
1	40001	0 X 01	Rate unit	1	USINT	R/W	Reset per second (RPS) : 0 Rate per Minute (RPM) : 1 Rate per Hour (RPH) : 2
2	40002	0 X 02	Counting mode	1	USINT	R/W	Unidirectional : 0 Bidirectional : 1, Quad : 2
3	40003	0 X 03	Resolution	1	USINT	R/W	1 : 0 0.1 : 4 0.01 : 3 0.001 : 2 0.0001 : 1
4	40004	0 X 04	Relay Repeat Mode	1	USINT	R/W	None : 0, AR : 1, TPR : 2
5	40005	0 X 05	Scale FactorExponent	1	USINT	R/W	0 : 0 1 : 1 2 : 2 -5 : 3 -4 : 4 -3 : 5 -2 : 6 -1 : 7
6	40006	0 X 06	Slave Id		USINT	R/W	Range : 0 To 255
7	40007	0 X 07	Baud Rate	1	USINT	R/W	9600 : 2, 19K2 : 3, 38K4 : 4 57K6 : 5, 115K : 6

S.NO	Modbus Address	Hex Address	Parameters	Length (Bytes)	Data type	R/W	Description
PMR, RHR							
1	40054	0 X 36	SCL	4	UDINT	R/W	Data Format : LSB- MSB For setting Scale factor= 1.23456, send 123456 (Do not consider decimal point)
2	40056	0 X 38	SPBT	4	UDINT	R/W	Data Format : LSB- MSB For SPBT = 1, response will be: 00 01 00 00
3	40058	0 X 3A	Time(Set time value)	4	TIME	R/W	Data Format : LSB- MSB For time = 1.2 sec, send 1200 Data in decimal (set time in ms)
4	40072	0 X 48	Set1	8	LREAL	R/W	Data Format : MSB-LSB For Set1 = 100.0, response will be: 0000 4059 0000 0000H
5	40076	0 X 4C	Set2	8	LREAL	R/W	Data Format : MSB-LSB

S.NO	Modbus Address	Hex Address	Parameters	Length (Bytes)	Data type	R/W	Description
RIR							
1	30014	0 X 0E	Batch Total	4	UDINT	R	Data Format : LSB- MSB
2	30016	0 X 10	Time(Run time value)	4	TIME	R	Data Format : LSB- MSB
3	30020	0 X 14	Count Total	8	LREAL	R	Data Format : MSB -LSB
4	30024	0 X 18	Cumulative Total	8	LREAL	R	Data Format : MSB-LSB
5	30028	0 X 1C	Rate	8	LREAL	R	Data Format : MSB-LSB

USER GUIDE

1. COUNTING DIRECTION

a. Unidirectional : The unit counts the number of pulses received at the CNT1 input and can be programmed to count upwards from zero towards the set point (**Up counting**), or to count downwards from the set point to zero (**down counting**).

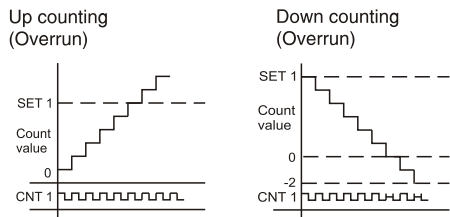

In Overrun mode, the unit continues to count above the set point.

b. Bi-directional :

In the Bi-directional mode of counting, the CNT2 input determines the count direction. If the CNT2 input is at level 1 (10V to 30V) XC200-NX counts up (increments) - open terminals 3 & 4. If the CNT2 input is at level 0 (0V to 1V) the XC200-NX counts down (decrements) - short terminals 3 & 4.

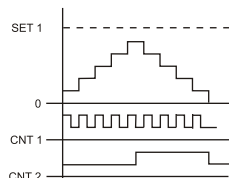

C. Quadrature : The Quadrature mode is suitable for using with sensors which generate 2 channels of output in quadrature (phase shift) e.g. Rotary encoders. The unit counts up (increments), if the CNT1 input transitions precede the CNT2 input transitions and counts down, if the CNT2 input transitions precede the CNT1 input transitions.

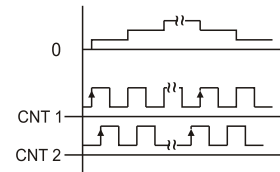

2. MODES OF OPERATION

a) On delay :

The output is energised at the end of the counting cycle (i.e. count value = set value) & remains on till unit is reset. When the number of pulses received is equal to SET2, relay 2 is switched ON, and when the number of pulses received equals Set1, relay 1 is switched ON. Both the outputs remain ON till the unit is reset.

Up counting (overrun mode)

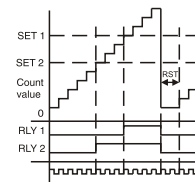

Down counting

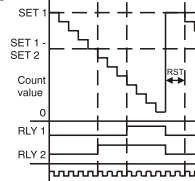

b) Interval:

The output is energised at the start of the counting cycle and de-energised on its completion. When the number of pulses received equal to SET2, relay2 is switched OFF, and when the number of pulses received equal to Set1, relay 1 is switched OFF. These relays remain OFF till the unit is reset.

Up counting (overrun mode)

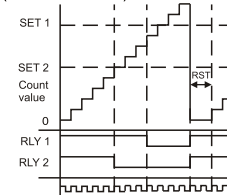

Down counting

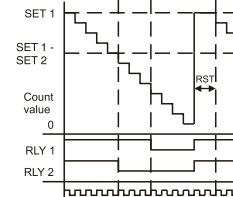

c) Time Pulse Repeat (TPR) :

The output changes state (according to the On delay or Interval mode selected) for a programmed pulse time (t), at the end of the count cycle. After the set pulse time, the count resets automatically & count cycle repeats. Counting continues uninterrupted during the pulse time.

Time Pulse Repeat (Up Counting, On Delay)

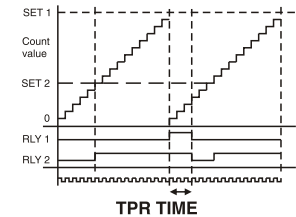

d) Auto-reset mode :

The output energises (according to the On delay or Interval delay mode selected) at the end of the count cycle for the programmed Auto reset time, after which the counter automatically resets and begins the next count cycle.

The unit remains reset for the Auto reset time and ignores count pulses received during this duration. It resumes operation only after this period has elapsed.

Auto Reset Mode (Up Counting, On Delay)

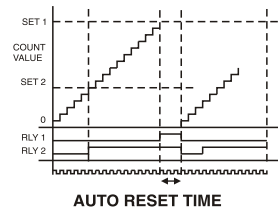

Overrun / Non Overrun feature:

Overrun: In overrun mode, the counter continues counting, after the SET1 value has been crossed.

Non overrun: In non overrun mode, the counter stops counting, after the SET1 value is reached and restarts counting only after reset.

SCALE FACTOR

The user programmable scale factor facilitates the direct reading in desired engineering unit. The counter multiplies the number of pulses received at the count input with the scale factor, and displays the result.

Count display = No. of pulses received x scale factor
Rate display = Number of pulses received per minute x scale factor or No. of pulses received per hour x scale factor.

The scale factor consists of two parts, mantissa and exponent.

The mantissa can be set from 0.00001 to 9.99999 and the exponent can be set from -5 to +2. The scale factor is arrived at as:

Scale factor = Mantissa X 10^{Exponent}

(Specifications are subject to change, since development is a continuous process.)

Selec Controls Pvt. Ltd., India

Factory Address :

EL-27/1, Electronic Zone, TTC Industrial Area, MIDC, Mahape, Navi Mumbai - 400 710, INDIA.

Tel. No. : +91-22-41 418 419/430 | Fax No. : +91-22-28471733

Toll free : 1800 227 353 (BSNL/MTNL Subscribers only)

Website : www.selec.com | Email : sales@selec.com